

Building Standards

100 Regina St. S.
2nd Floor
Waterloo, Ontario
N2J 4A8

Ph: 519-747-8712
Fx: 519-747-8792
www.waterloo.ca

Revised:
January 2016

Egress Window &
Window Well
Detail

Drawing No.:

4

380mm (15") OR MORE FOR
OPENABLE PORTION OF WINDOW

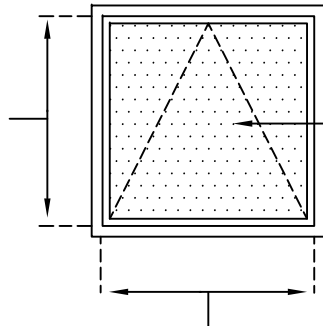

MINIMUM AREA OF UNOBSTRUCTED
OPENING NOT LESS THAN 0.35m²
(3.8ft²) WITH NO DIMENSION LESS
THAN 380mm (15")

380mm (15") OR MORE FOR
OPENABLE PORTION OF WINDOW

380mm (15") OR MORE FOR
OPENABLE PORTION OF WINDOW

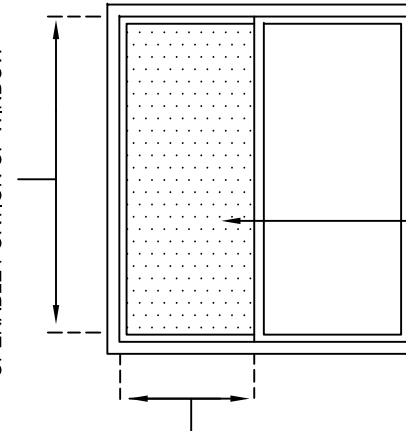

MINIMUM AREA OF UNOBSTRUCTED
OPENING NOT LESS THAN 0.35m²
(3.8ft²) WITH NO DIMENSION LESS
THAN 380mm (15")

380mm (15") OR MORE FOR
OPENABLE PORTION OF WINDOW

**EGRESS WINDOW SERVING A BASEMENT
CONTAINING BEDROOM(S)**

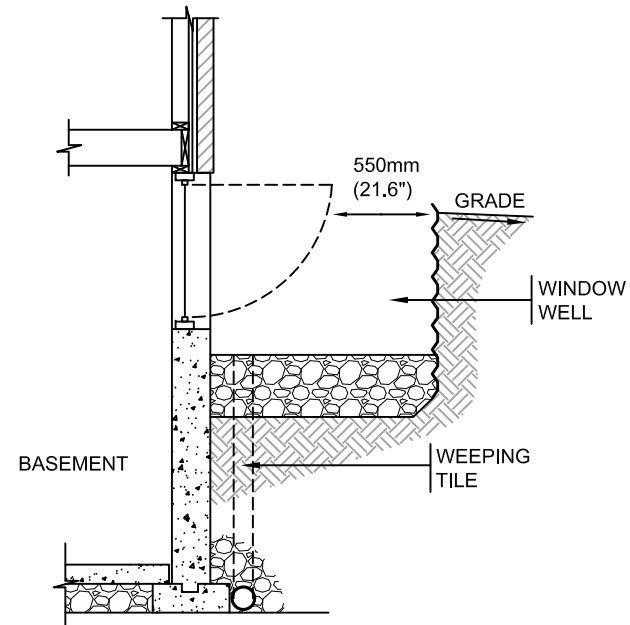
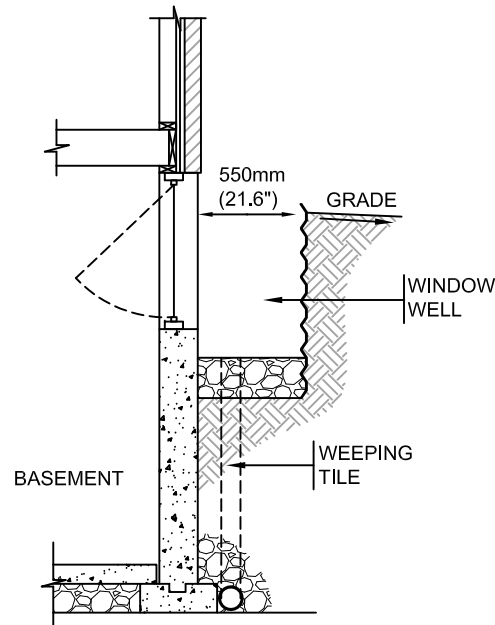

**WINDOW WELL FOR AN EGRESS WINDOW SERVING A
BASEMENT CONTAINING BEDROOM(S)**